



3933 US ROUTE 11, CORTLAND, NEW YORK 13045, U.S.A.  
Phone Number: 1-800-345-3851 Fax Number: 607-758-3648

PROJECT NO.: 3030592-311

DATE: April 5, 2010

TEST REPORT NO.: 3030592CRT-058

RENDERED TO:



Ortronics Incorporated  
125 Eugene O'Neil Drive  
New London, CT 06320



Ph (860) 445-3800 / Fax (860) 405-2970

**TEST:**

Performance testing of the cabling configurations as defined in and to the requirements of ANSI/TIA-568-C.2 Balanced Twisted-Pair Telecommunications Cabling and Components Standard.

**STATEMENT OF LIMITATIONS:**

The purpose of this report is to provide electrical performance data on the test sample. It is not valid to use this report for any other purpose.

**STANDARDS USED:**

ANSI/TIA-568-C.2 Balanced Twisted-Pair Telecommunications Cabling and Components Standard approved August 11, 2009.

**AUTHORIZATION:**

The project was authorized by Robert Aekins, representing, Ortronics Incorporated.

**SPECIMEN DESCRIPTION:**

GTX CAT 6a Channel, 7 meters, 2-Connector

**DATE OF TEST:**

16 September 2009

**TEST REPORT REVISION HISTORY:**

First Issue:	04-05-2010	Original Document
--------------	------------	-------------------

This report is for the exclusive use of Intertek's Client and is provided pursuant to the agreement between Intertek and its Client. Intertek's responsibility and liability are limited to the terms and conditions of the agreement. Intertek assumes no liability to any party, other than to the Client in accordance with the agreement, for any loss, expense or damage occasioned by the use of this report. Only the Client is authorized to copy or distribute this report and then only in its entirety. Any use of the Intertek name or one of its marks for the sale or advertisement of the tested material, product or service must first be approved in writing by Intertek. The observations and test results in this report are relevant only to the sample tested. This report by itself does not imply that the material, product, or service is or has ever been under an Intertek certification program.

**SAMPLE DESCRIPTION:**

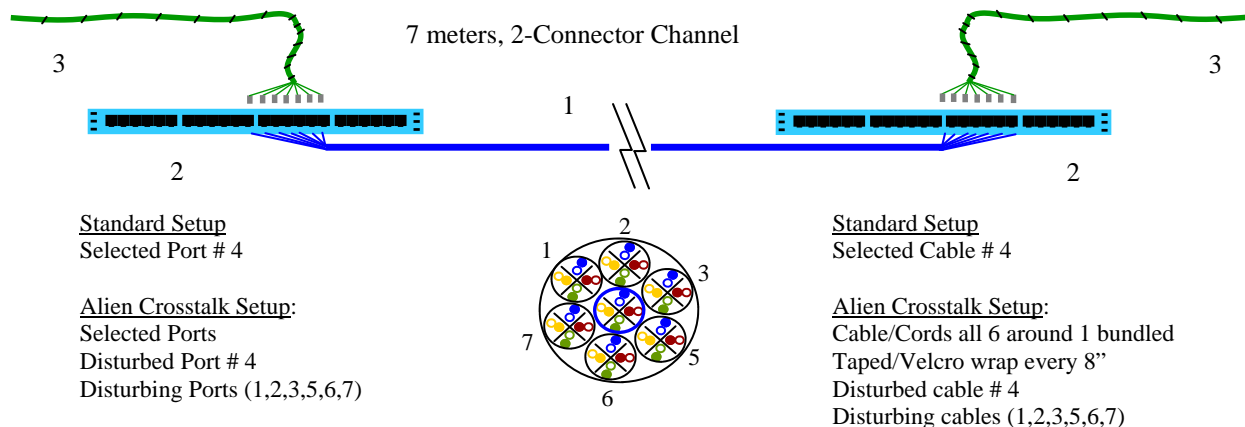

Component ID	Manufacturer	Part Number	Length/Qty	Description
1	BerkTek	BerkTek LANMark 10G2	5 Meters	Horizontal Cable, C6A UTP CMP
2	Ortronics, Inc.	OR-PHA610U24	2	Clarity 10G Patch Panels
3	Ortronics, Inc.	OR-MC61003-09	2	Clarity 10G Patch Cords, 3 ft

**EQUIPMENT LIST:**

The following equipment was employed in conducting the tests.

Equipment Used	Model Number	Serial Number	Control Number	Calibration Date
Agilent Technologies Network Analyzer	E5071B	MY42403324	N/A	06/3/2009
Hewlett Packard Multimeter	34401A	US36035667	N/A	06/3/2009

**RESULTS:**

See appendixes A through C for the test results.

**CONCLUSION:**

The channel configuration, as previously described, was tested under the SAT program of Intertek in accordance with the standard contained herein, and did comply with the indicated applicable transmission requirements.

These procedures and requirements were taken from the standards referred to on page 1.

Reviewed and approved by:

*Antoine Pelletier*  
 Antoine Pelletier  
 Engineer  
 Global Cabling Products Testing

*Kathy Heath*  
 Kathy Heath  
 Program Coordinator  
 Global Cabling Products Testing

## APPENDIX A

### Test Results

Internal (core) transmission characteristics of the “disturbed” channel

Any data shown above 500 MHz is for indication only.

This appendix contains 7 pages.



**NEXT as measured from the TELECOMMUNICATIONS ROOM (TR)**

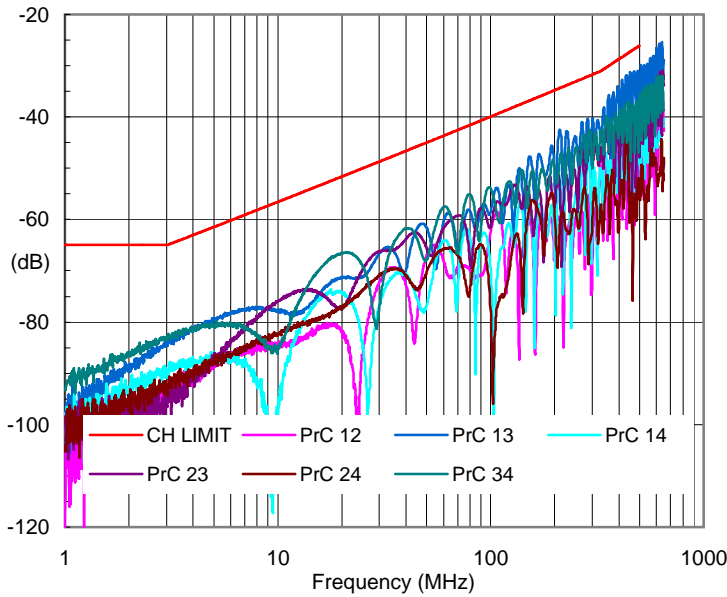

Worst Case Margin				
	Frequency Point (MHz)	Calculated Margin (dB)	Measured Value (dB)	CH LIMIT Value (dB)
Swept Freq	452.3	4.0	31.3	27.3
Discrete Points	1.00	27.9	92.9	65.0
	4.00	18.3	81.3	63.0
	8.00	19.2	77.3	58.2
	10.00	19.4	75.9	56.6
	16.00	16.1	69.4	53.2
	20.00	15.0	66.6	51.6
	25.00	19.0	69.0	50.0
	31.25	17.5	65.9	48.4
	62.50	14.4	57.8	43.4
	100.00	14.1	54.0	39.9
	200.00	15.2	50.0	34.8
	250.00	10.7	43.8	33.1
	300.00	8.7	40.5	31.7
	400.00	7.4	36.1	28.7
	500.00	10.9	37.0	26.1
650.00			28.9	n/a

**NEXT as measured from the WORK AREA (WA)**

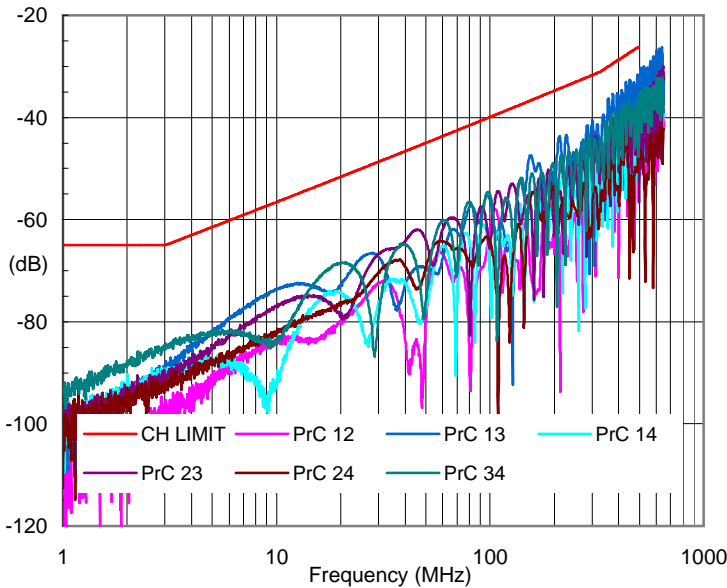

Worst Case Margin				
	Frequency Point (MHz)	Calculated Margin (dB)	Measured Value (dB)	CH LIMIT Value (dB)
Swept Freq	432.7	5.3	33.1	27.8
Discrete Points	1.00	27.9	92.9	65.0
	4.00	20.4	83.4	63.0
	8.00	17.7	75.9	58.2
	10.00	17.0	73.6	56.6
	16.00	17.8	71.0	53.2
	20.00	16.8	68.5	51.6
	25.00	17.5	67.5	50.0
	31.25	17.8	66.2	48.4
	62.50	17.0	60.3	43.4
	100.00	15.3	55.2	39.9
	200.00	15.3	50.1	34.8
	250.00	15.4	48.5	33.1
	300.00	9.1	40.9	31.7
	400.00	9.2	37.9	28.7
	500.00	10.9	37.0	26.1
650.00			31.2	n/a



PSNEXT as measured from the TELECOMMUNICATIONS ROOM (TR)

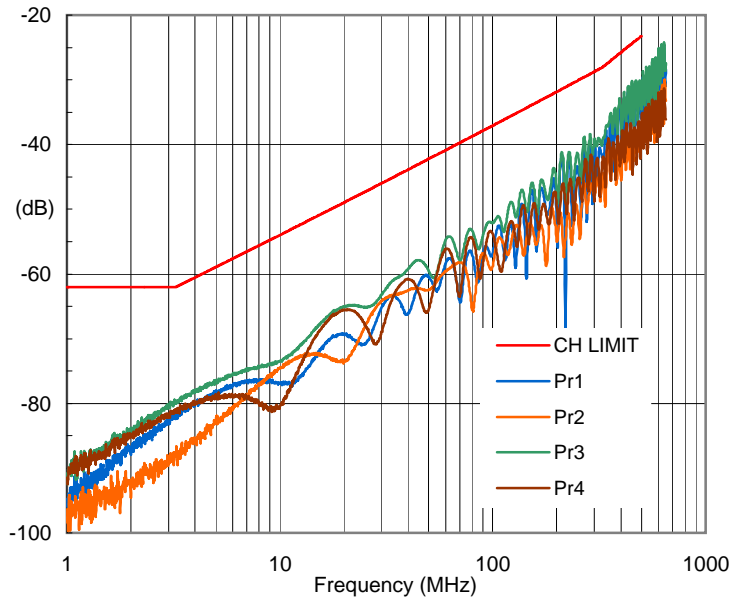

Worst Case Margin				
	Frequency Point (MHz)	Calculated Margin (dB)	Calculated Value (dB)	CH LIMIT Value (dB)
Swept Freq	452.3	5.8	30.2	24.4
Discrete Points	1.00	28.9	90.9	62.0
	4.00	17.8	78.4	60.5
	8.00	18.8	74.4	55.6
	10.00	19.5	73.5	54.0
	16.00	16.7	67.3	50.6
	20.00	16.1	65.1	49.0
	25.00	17.8	65.2	47.3
	31.25	16.8	62.5	45.7
	62.50	13.6	54.2	40.6
	100.00	15.0	52.1	37.1
	200.00	15.6	47.5	31.9
	250.00	11.2	41.3	30.2
	300.00	10.6	39.4	28.8
	400.00	9.3	35.1	25.8
	500.00	10.6	33.8	23.2
650.00			27.4	n/a

PSNEXT as measured from the WORK AREA (WA)

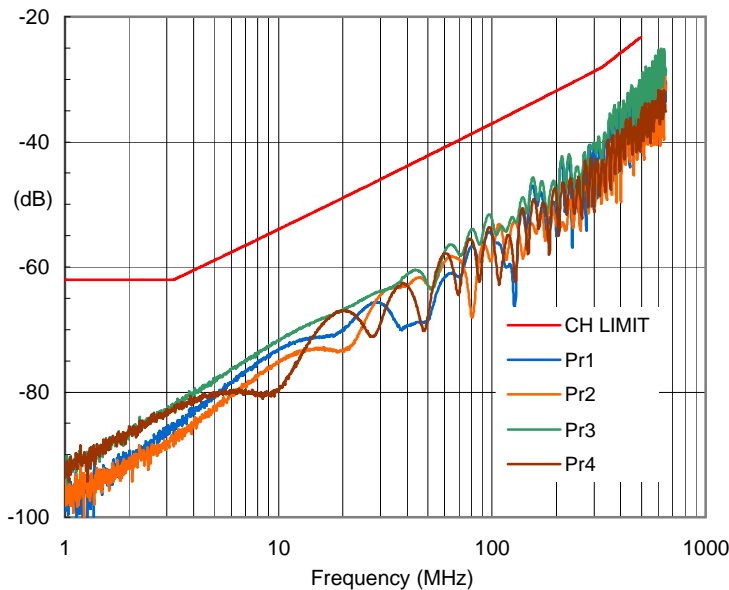

Worst Case Margin				
	Frequency Point (MHz)	Calculated Margin (dB)	Calculated Value (dB)	CH LIMIT Value (dB)
Swept Freq	450.6	6.5	30.9	24.4
Discrete Points	1.00	29.7	91.7	62.0
	4.00	19.7	80.3	60.5
	8.00	18.2	73.8	55.6
	10.00	17.8	71.8	54.0
	16.00	17.6	68.2	50.6
	20.00	17.8	66.8	49.0
	25.00	17.8	65.1	47.3
	31.25	18.0	63.7	45.7
	62.50	16.0	56.6	40.6
	100.00	15.4	52.5	37.1
	200.00	16.4	48.2	31.9
	250.00	13.8	44.0	30.2
	300.00	11.2	40.0	28.8
	400.00	11.3	37.1	25.8
	500.00	12.7	35.9	23.2
650.00			28.4	n/a



RL as measured from the TELECOMMUNICATIONS ROOM (TR)

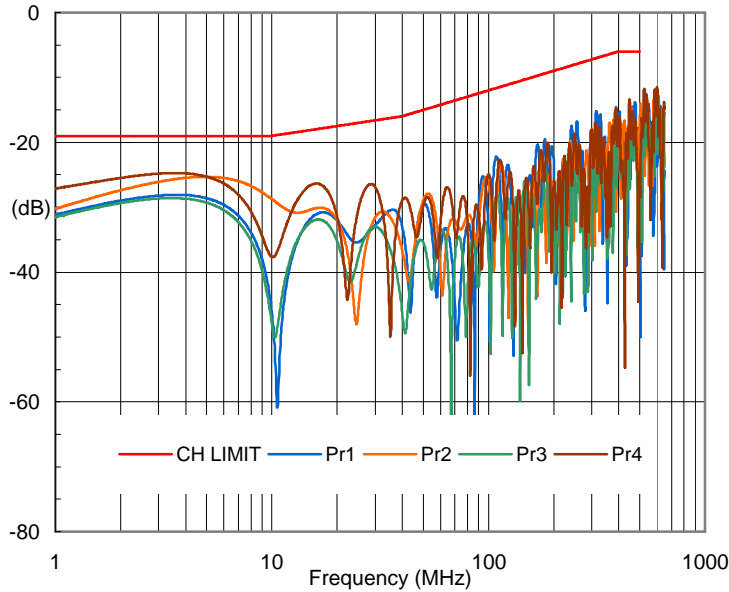

Worst Case Margin				
	Frequency Point (MHz)	Calculated Margin (dB)	Measured Value (dB)	CH LIMIT Value (dB)
Swept Freq	3.5	5.7	24.7	19.0
Discrete Points	1.00	8.1	27.1	19.0
	4.00	5.8	24.8	19.0
	8.00	7.7	26.7	19.0
	10.00	9.8	28.8	19.0
	16.00	8.4	26.4	18.0
	20.00	13.9	31.4	17.5
	25.00	13.5	30.5	17.0
	31.25	11.7	28.2	16.5
	62.50	13.9	28.0	14.0
	100.00	12.9	24.9	12.0
	200.00	14.3	23.3	9.0
	250.00	10.7	18.7	8.0
	300.00	11.0	18.2	7.2
	400.00	10.2	16.2	6.0
	500.00	9.8	15.8	6.0
650.00			14.9	n/a

RL as measured from the WORK AREA (WA)

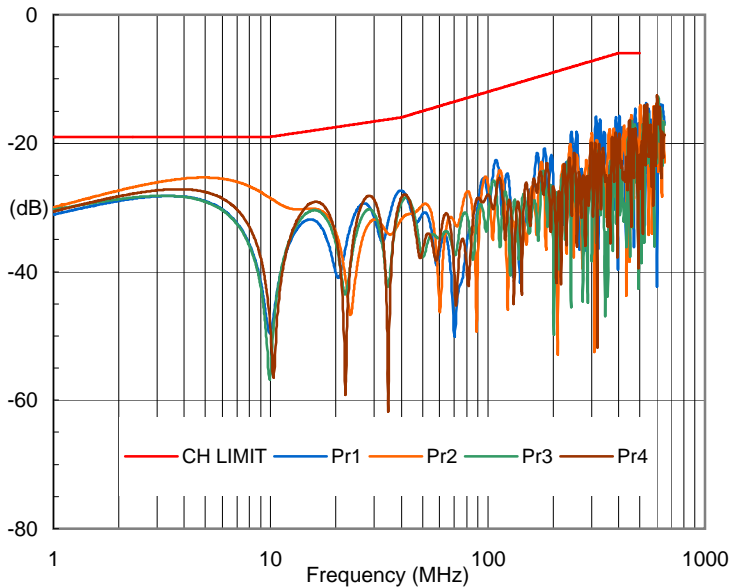

Worst Case Margin				
	Frequency Point (MHz)	Calculated Margin (dB)	Measured Value (dB)	CH LIMIT Value (dB)
Swept Freq	4.9	6.3	25.3	19.0
Discrete Points	1.00	11.0	30.0	19.0
	4.00	6.5	25.5	19.0
	8.00	7.7	26.7	19.0
	10.00	9.6	28.6	19.0
	16.00	11.1	29.1	18.0
	20.00	16.4	33.9	17.5
	25.00	13.4	30.4	17.0
	31.25	13.9	30.4	16.5
	62.50	17.7	31.7	14.0
	100.00	14.1	26.1	12.0
	200.00	15.9	24.9	9.0
	250.00	13.6	21.6	8.0
	300.00	11.4	18.6	7.2
	400.00	13.5	19.5	6.0
	500.00	10.2	16.2	6.0
650.00			16.9	n/a



ACRF

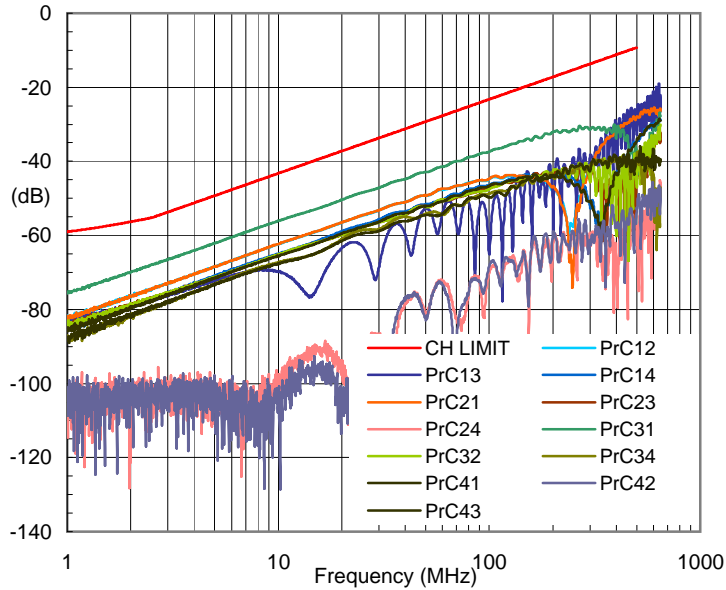

Worst Case Margin

	Frequency Point (MHz)	Calculated Margin (dB)	Measured Value (dB)	CH LIMIT Value (dB)
Swept Freq	2.6	12.6	67.4	54.8
Discrete Points	1.00	16.6	75.6	59.0
	4.00	12.8	64.0	51.2
	8.00	12.8	58.0	45.2
	10.00	12.8	56.1	43.3
	16.00	13.3	52.4	39.2
	20.00	13.2	50.4	37.2
	25.00	13.1	48.4	35.3
	31.25	13.4	46.8	33.4
	62.50	13.9	41.2	27.3
	100.00	14.1	37.4	23.3
	200.00	14.9	32.1	17.2
	250.00	16.0	31.3	15.3
	300.00	17.8	31.5	13.7
	400.00	20.1	31.3	11.2
500.00	18.5	27.8	9.3	
650.00			22.1	n/a

PSACRF

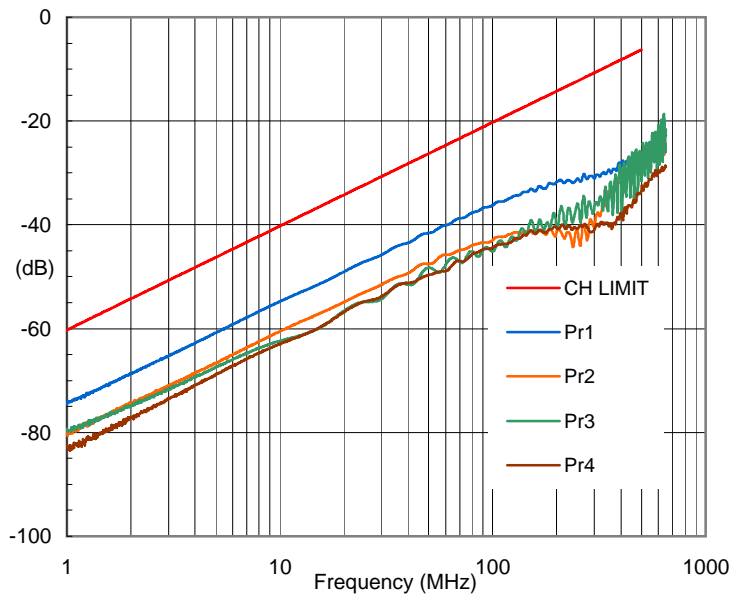

Worst Case Margin

	Frequency Point (MHz)	Calculated Margin (dB)	Calculated Value (dB)	CH LIMIT Value (dB)
Swept Freq	1.0	13.9	74.1	60.2
Discrete Points	1.00	14.3	74.6	60.3
	4.00	14.5	62.7	48.2
	8.00	14.5	56.7	42.2
	10.00	14.5	54.8	40.3
	16.00	14.9	51.1	36.2
	20.00	14.8	49.1	34.2
	25.00	14.8	47.1	32.3
	31.25	15.1	45.4	30.4
	62.50	15.6	39.9	24.3
	100.00	16.0	36.2	20.3
	200.00	17.5	31.7	14.2
	250.00	18.8	31.1	12.3
	300.00	20.4	31.1	10.7
	400.00	21.3	29.5	8.2
500.00	20.5	26.7	6.3	
650.00			21.6	n/a



TCL as measured from the TELECOMMUNICATIONS ROOM (TR)

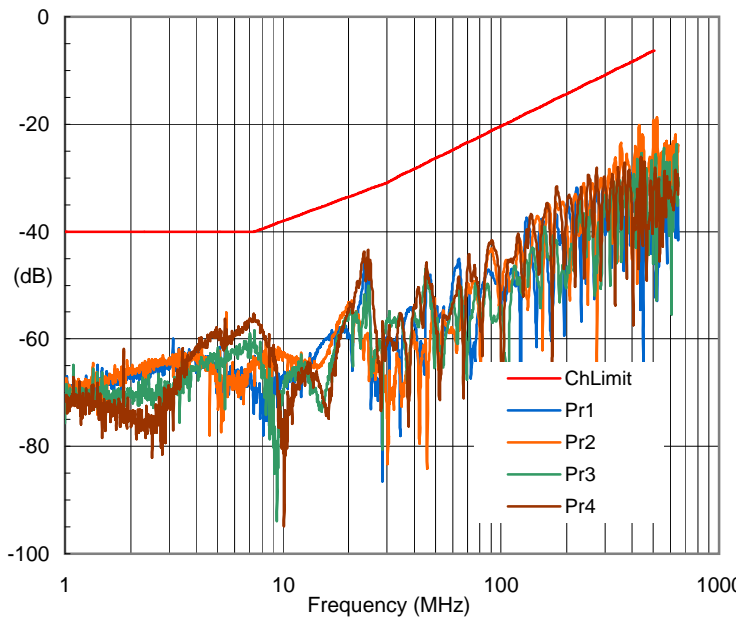

Worst Case Margin				
	Frequency Point (MHz)	Calculated Margin (dB)	Calculated Value (dB)	CH LIMIT Value (dB)
Swept Freq	24.5	11.2	43.4	32.2
Discrete Points	1.00	28.8	68.8	40.0
	4.00	21.5	61.5	40.0
	8.00	19.4	58.9	39.5
	10.00	24.7	62.7	38.0
	16.00	25.1	60.1	34.9
	20.00	19.7	53.2	33.5
	25.00	13.4	45.5	32.0
	31.25	26.4	56.8	30.4
	62.50	22.0	46.4	24.4
	100.00	30.3	50.6	20.3
	200.00	19.5	33.8	14.3
	250.00	17.3	29.6	12.3
	300.00	22.2	33.0	10.8
	400.00	20.5	28.7	8.3
	500.00	16.2	22.5	6.3
650.00			25.2	n/a

TCL as measured from the WORK AREA (WA)

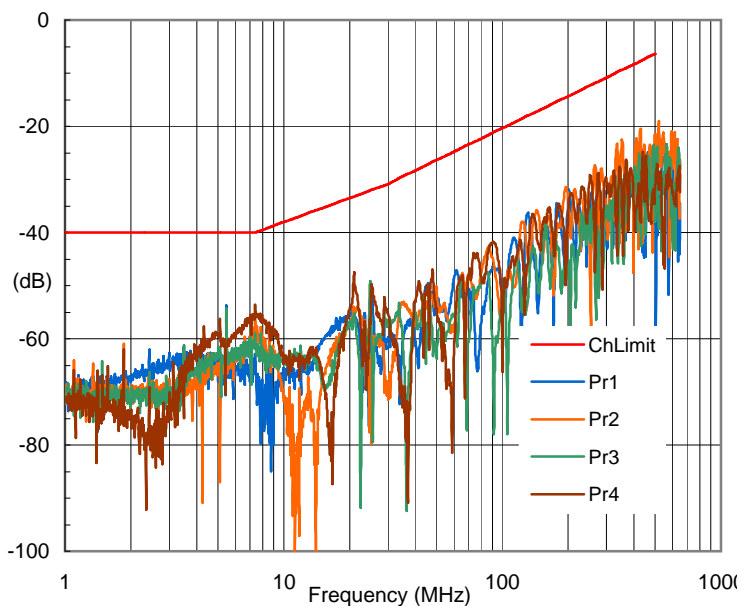

Worst Case Margin				
	Frequency Point (MHz)	Calculated Margin (dB)	Calculated Value (dB)	CH LIMIT Value (dB)
Swept Freq	423.2	12.7	20.5	7.8
Discrete Points	1.00	99.5	70.9	40.0
	4.00	84.4	62.9	40.0
	8.00	76.1	56.7	39.5
	10.00	88.3	63.6	38.0
	16.00	83.7	77.9	34.9
	20.00	73.6	54.0	33.5
	25.00	63.6	54.4	32.0
	31.25	83.1	60.4	30.4
	62.50	70.6	49.6	24.4
	100.00	81.6	55.6	20.3
	200.00	51.7	33.6	14.3
	250.00	47.0	29.8	12.3
	300.00	54.5	32.2	10.8
	400.00	44.9	39.5	8.3
	500.00	42.8	29.2	6.3
650.00			32.4	n/a



ELTCTL as measured from the TELECOMMUNICATIONS ROOM (TR)

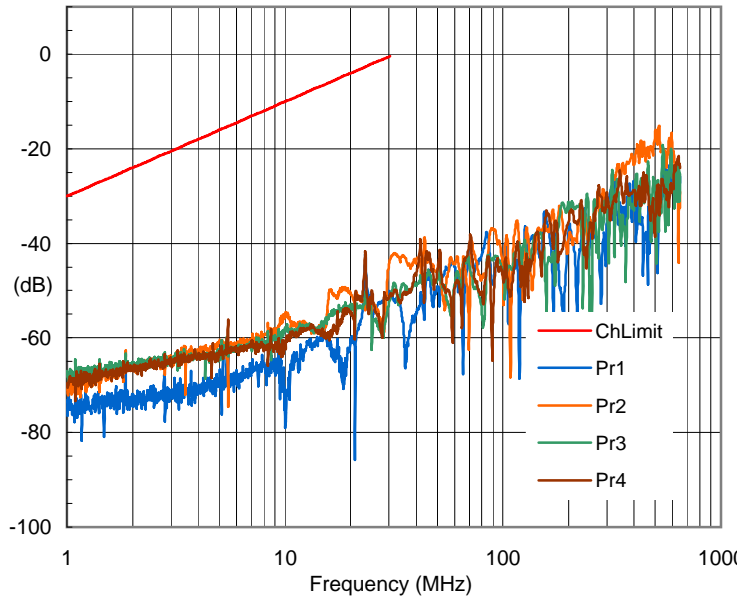

Worst Case Margin				
	Frequency Point (MHz)	Calculated Margin (dB)	Calculated Value (dB)	CH LIMIT Value (dB)
Swept Freq	1.1	35.3	64.6	29.3
Discrete Points	1.00	37.0	67.0	30.0
	4.00	44.7	62.6	18.0
	8.00	47.3	59.2	11.9
	10.00	44.7	54.7	10.0
	16.00	44.1	50.0	5.9
	20.00	46.9	50.8	4.0
	25.00	48.0	50.0	2.0
	31.25		42.2	n/a
	62.50		45.3	n/a
	100.00		42.8	n/a
	200.00		33.2	n/a
	250.00		34.5	n/a
	300.00		31.9	n/a
	400.00		21.5	n/a
500.00		16.9	n/a	
650.00		24.1	n/a	

ELTCTL as measured from the WORK AREA (WA)

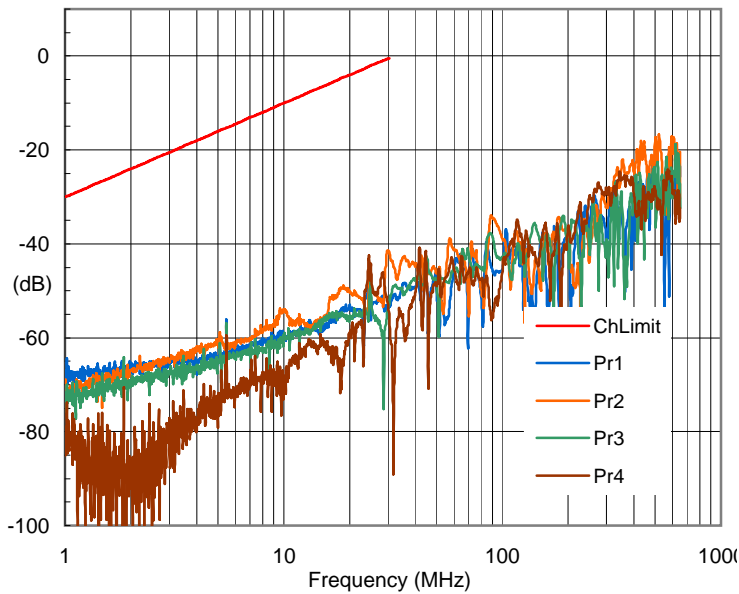

Worst Case Margin				
	Frequency Point (MHz)	Calculated Margin (dB)	Calculated Value (dB)	CH LIMIT Value (dB)
Swept Freq	1.0	34.6	64.4	29.8
Discrete Points	1.00	38.7	68.7	30.0
	4.00	44.8	62.7	18.0
	8.00	46.2	58.1	11.9
	10.00	44.0	54.0	10.0
	16.00	46.4	52.3	5.9
	20.00	46.3	50.3	4.0
	25.00	42.3	44.4	2.0
	31.25		44.0	n/a
	62.50		42.7	n/a
	100.00		39.2	n/a
	200.00		37.1	n/a
	250.00		29.8	n/a
	300.00		29.6	n/a
	400.00		23.8	n/a
500.00		18.5	n/a	
650.00		20.4	n/a	



INSERTION LOSS (ATTN)

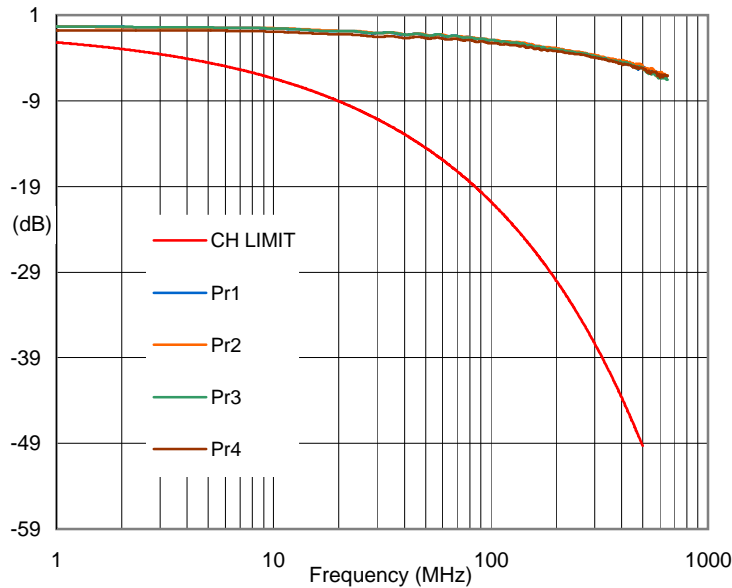

Worst Case Margin

	Frequency Point (MHz)	Calculated Margin (dB)	Measured Value (dB)	CH LIMIT Value (dB)
Swept Freq	1.00	1.43	0.76	2.19
Discrete Points	1.00	1.43	0.8	2.2
	4.00	3.28	0.8	4.1
	8.00	4.86	0.9	5.7
	10.00	5.47	0.9	6.4
	16.00	6.94	1.2	8.1
	20.00	7.83	1.2	9.1
	25.00	8.81	1.3	10.2
	31.25	9.85	1.5	11.4
	62.50	14.42	1.8	16.3
	100.00	18.49	2.3	20.8
	200.00	26.79	3.2	30.0
	250.00	30.23	3.6	33.8
	300.00	33.35	3.9	37.3
	400.00	38.94	4.7	43.6
500.00	44.08	5.2	49.3	
650.00		6.6	n/a	

DC Resistance Unbalance (%)

ChnlLimit	Pr1	Pr2	Pr3	Pr4	MaxValue	MinMargin
3	0.559	0.535	0.571	0.571	0.571	2.429

GLOSSARY of TERMS

- Calculated Margin:** The minimum difference in dB between the measured value and the LIMIT value at the specified frequency point for all tested pairs (CalculateMargin@100MHz = MeasuredValue@100MHz - LIMITValue@100MHz (dB)).
- Discrete Points:** Specific reference points of interest in MHz within the swept frequencies.
- Frequency Point:** A specific frequency point in megahertz (MHz) for which the data indicated is applicable.
- LIMIT Value:** The calculated response LIMIT in dB at the indicated frequency point as calculated using applicable equation defined by the appropriate standard.
- Measured Value:** The worst case measured response in dB at the frequency indicated for all tested pairs.
- Swept Freq:** The band of measured values from 1 MHz to the upper frequency LIMIT as defined by the category of test.
- Swept Freq (Margin):** The minimum margin in dB detected across the Swept Frequency band.
- Worst Case:** A composite value calculated from the maximum response of each pair or pair combination at a given frequency (WorstCase<sub>100MHz</sub> = Max(Pr1<sub>100MHz</sub>, Pr2<sub>100MHz</sub>, Pr3<sub>100MHz</sub>, Pr4<sub>100MHz</sub>) etc).
- ACR / PSACR:** If Provided are for reference only. Limit line(s) are provided for reference and are calculated as the difference between the applicable NEXT Loss and Insertion loss limits (ACR<sub>limit</sub> = NEXT<sub>limit</sub> - I<sub>limit</sub>).

**APPENDIX B**

Test results

Alien transmission characteristics (6 around 1 test configuration)

Any data reported above 500 MHz is for indication only.

This contains appendix 2 pages.



**PowerSum Alien Near-End Crosstalk (PSANEXT)**

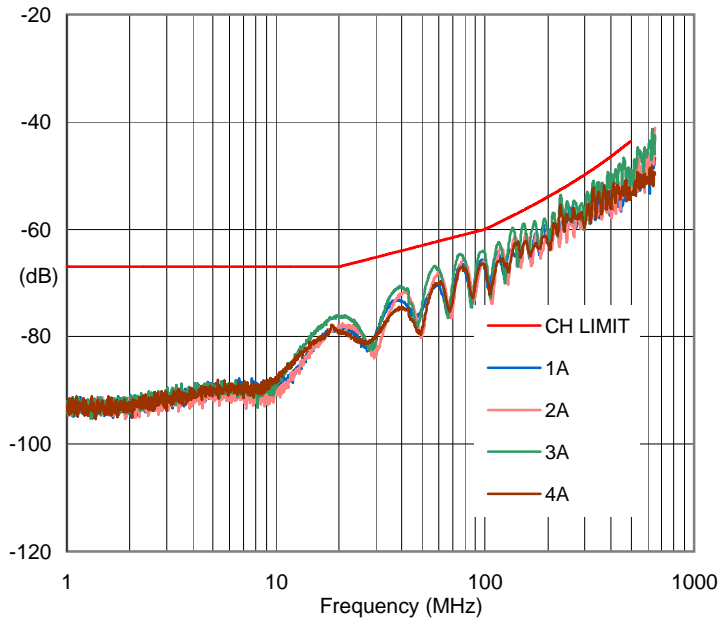

Worst Case Margin				
	Frequency Point (MHz)	Calculated Margin (dB)	Measured Value (dB)	CH LIMIT Value (dB)
Swept Freq	230.7	1.0	-53.6	-52.6
Discrete Points	1.00	25.0	92.0	67.0
	4.00	23.7	90.7	67.0
	8.00	22.9	89.9	67.0
	10.00	21.9	88.9	67.0
	16.00	11.3	78.3	67.0
	20.00	9.1	76.1	67.0
	25.00	12.3	78.4	66.0
	31.25	12.7	77.7	65.1
	62.50	6.9	69.0	62.0
	100.00	4.7	64.7	60.0
	200.00	6.5	60.5	54.0
	250.00	3.6	55.4	51.8
	300.00	7.2	57.1	49.8
	400.00	4.7	51.2	46.5
	500.00	5.5	49.1	43.5
	650.00		41.0	n/a

**Average PowerSum Alien Near-End Crosstalk (avgPSANEXT)**

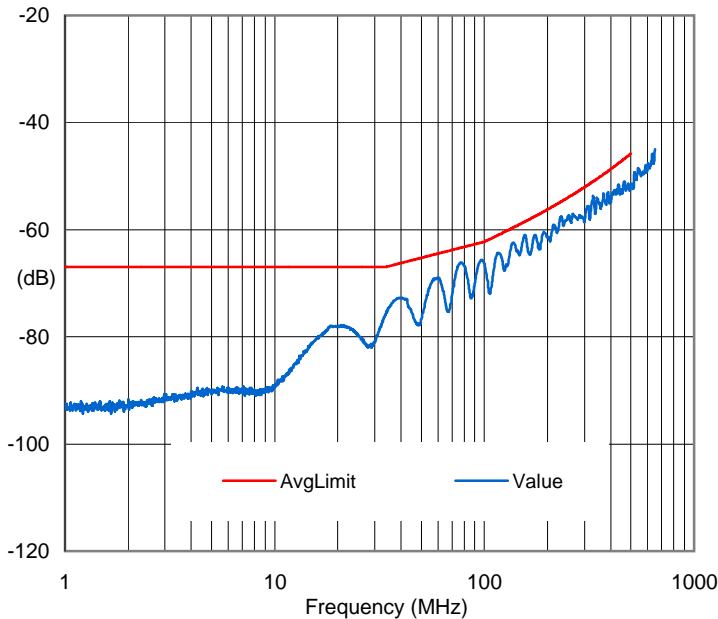

Worst Case Margin				
	Frequency Point (MHz)	Calculated Margin (dB)	Measured Value (dB)	CH LIMIT Value (dB)
Swept Freq	156.4	2.5	-61.0	-58.5
Discrete Points	1.00	25.7	92.7	67.0
	4.00	23.9	90.9	67.0
	8.00	23.4	90.4	67.0
	10.00	22.9	89.9	67.0
	16.00	13.1	80.1	67.0
	20.00	11.1	78.1	67.0
	25.00	12.8	79.8	67.0
	31.25	12.2	79.2	67.0
	62.50	6.0	70.3	64.3
	100.00	4.2	66.4	62.3
	200.00	5.2	61.4	56.2
	250.00	3.7	57.7	54.0
	300.00	6.5	58.6	52.1
	400.00	6.2	54.9	48.7
	500.00	6.1	51.9	45.8
	650.00		45.0	n/a



**Power Sum Attenuation to Alien Crosstalk Ratio Far-End (PSAACRF)**

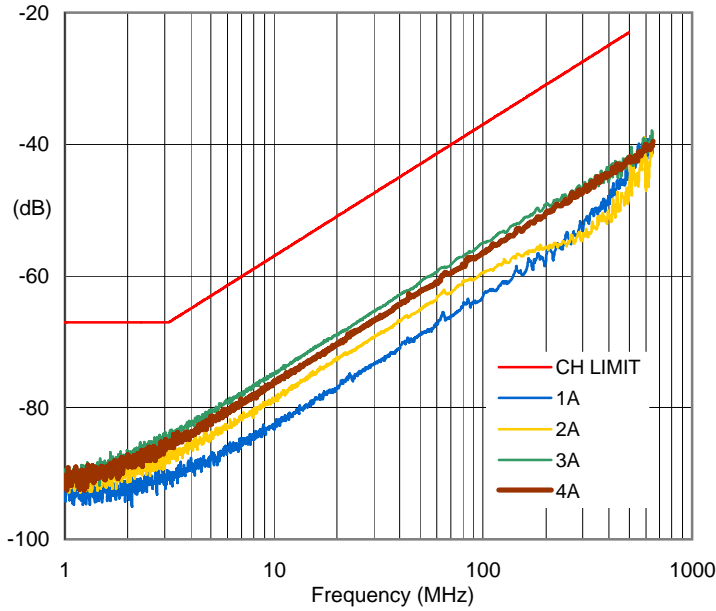

Worst Case Margin				
	Frequency Point (MHz)	Calculated Margin (dB)	Calculated Value (dB)	CH LIMIT Value (dB)
Swept Freq	3.2	16.5	-83.4	-66.9
Discrete Points	1.00	23.3	90.3	67.0
	4.00	17.4	82.4	65.0
	8.00	17.8	76.8	58.9
	10.00	17.9	74.9	57.0
	16.00	17.7	70.7	52.9
	20.00	18.0	69.0	51.0
	25.00	18.0	67.0	49.0
	31.25	17.9	65.0	47.1
	62.50	17.7	58.8	41.1
	100.00	18.0	55.0	37.0
	200.00	18.2	49.1	31.0
	250.00	18.9	47.9	29.0
	300.00	19.0	46.5	27.5
	400.00	19.6	44.5	25.0
	500.00	19.4	42.4	23.0
	650.00		38.4	n/a

**Average Power Sum Attenuation to Alien Crosstalk Ratio Far-End (avgPSAACRF)**

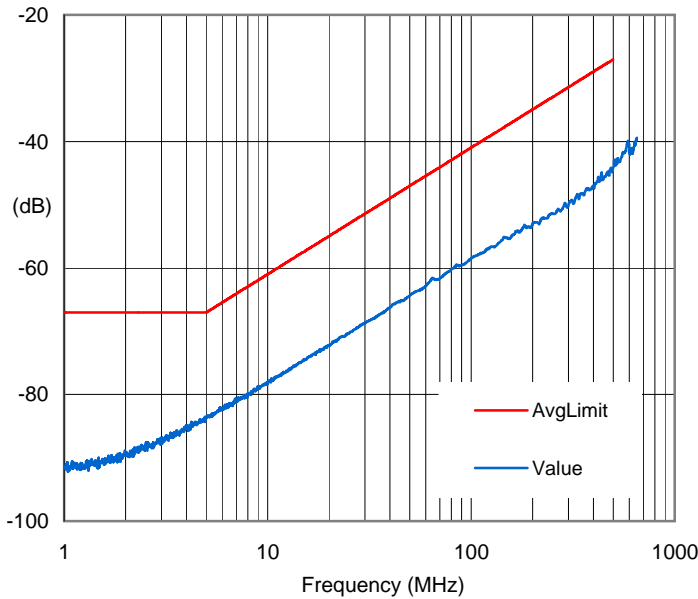

Worst Case Margin				
	Frequency Point (MHz)	Calculated Margin (dB)	Calculated Value (dB)	CH LIMIT Value (dB)
Swept Freq	5.9	16.4	-82.0	-65.6
Discrete Points	1.00	24.6	91.6	67.0
	4.00	17.9	84.9	67.0
	8.00	13.0	80.0	62.9
	10.00	11.3	78.3	61.0
	16.00	7.1	74.1	56.9
	20.00	5.2	72.2	55.0
	25.00	3.3	70.3	53.0
	31.25	1.4	68.4	51.1
	62.50	-2.1	62.2	45.1
	100.00	-3.7	58.5	41.0
	200.00	-3.1	53.1	35.0
	250.00	-2.7	51.4	33.0
	300.00	-1.9	50.2	31.5
	400.00	-1.4	47.4	29.0
	500.00	-1.7	44.1	27.0
	650.00		39.4	n/a

**APPENDIX C**

Test results

ACR transmission performance provided for reference ONLY

Any data reported above 500 MHz is for indication only.

This appendix contains 2 pages.



Pair-to-Pair ACR as measured from the TELECOMMUNICATIONS ROOM (TR)

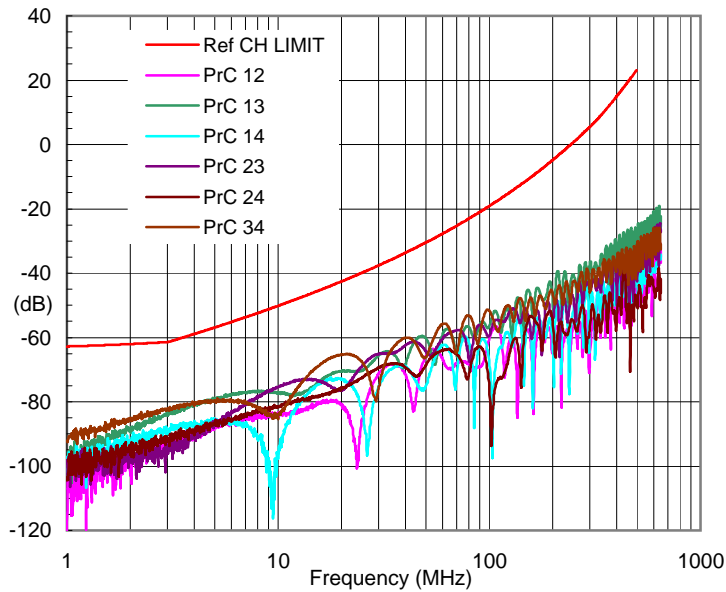

**NOTE:** Limit line/values provided for reference ONLY and are extrapolated from NEXT Loss and IL limit requirements.  $ACR_{limit} = NEXT_{limit} - IL_{limit}$

**Worst Case Margin**

	Frequency Point (MHz)	Calculated Margin (dB)	Calculated Value (dB)	CH LIMIT Value (dB)
<b>Swept Freq</b>	<b>3.1</b>	<b>20.2</b>	<b>-81.5</b>	<b>-61.3</b>
<b>Discrete Points</b>	1.00	-58.2	-121.0	-62.8
	4.00	-31.9	-90.8	-59.0
	8.00	-39.0	-91.4	-52.4
	10.00	-46.8	-96.9	-50.2
	16.00	-35.0	-80.1	-45.1
	20.00	-38.3	-80.9	-42.6
	25.00	-45.8	-85.7	-39.9
	31.25	-35.7	-72.8	-37.0
	62.50	-42.1	-69.3	-27.1
	100.00	-57.0	-76.1	-19.2
	200.00	-58.9	-63.7	-4.8
	250.00	-57.2	-56.5	0.7
	300.00	-71.5	-66.0	5.5
	400.00	-71.0	-56.1	14.9
	500.00	-72.5	-49.3	23.2
	650.00		-41.8	n/a

Pair-to-Pair ACR as measured from the WORK AREA (WA)

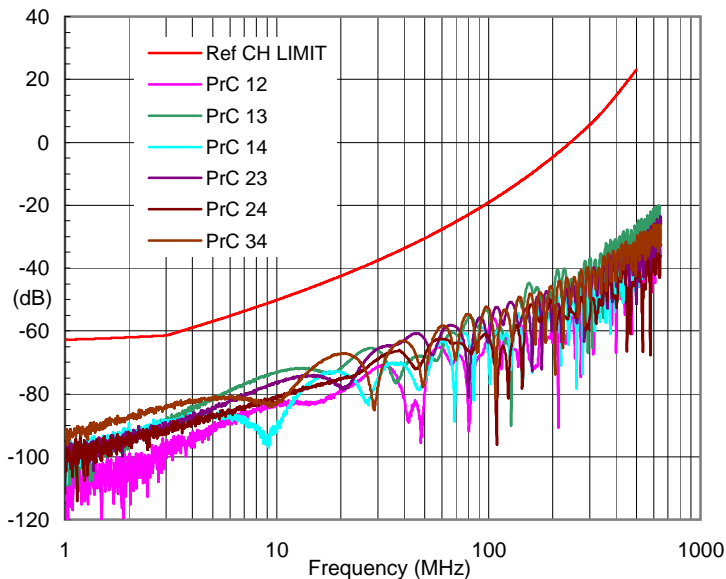

**Worst Case Margin**

	Frequency Point (MHz)	Calculated Margin (dB)	Calculated Value (dB)	CH LIMIT Value (dB)
<b>Swept Freq</b>	<b>3.4</b>	<b>22.1</b>	<b>-82.5</b>	<b>-60.5</b>
<b>Discrete Points</b>	1.00	-50.8	-113.6	-62.8
	4.00	-34.4	-93.3	-59.0
	8.00	-37.9	-90.3	-52.4
	10.00	-41.5	-91.7	-50.2
	16.00	-37.2	-82.4	-45.1
	20.00	-36.4	-79.0	-42.6
	25.00	-39.4	-79.3	-39.9
	31.25	-36.0	-73.0	-37.0
	62.50	-40.0	-67.1	-27.1
	100.00	-50.6	-69.7	-19.2
	200.00	-58.1	-63.0	-4.8
	250.00	-56.5	-55.8	0.7
	300.00	-61.3	-55.8	5.5
	400.00	-80.8	-65.9	14.9
	500.00	-70.0	-46.8	23.2
	650.00		-36.2	n/a



Power Sum (PS) ACR as measured from the TELECOMMUNICATIONS ROOM (TR)

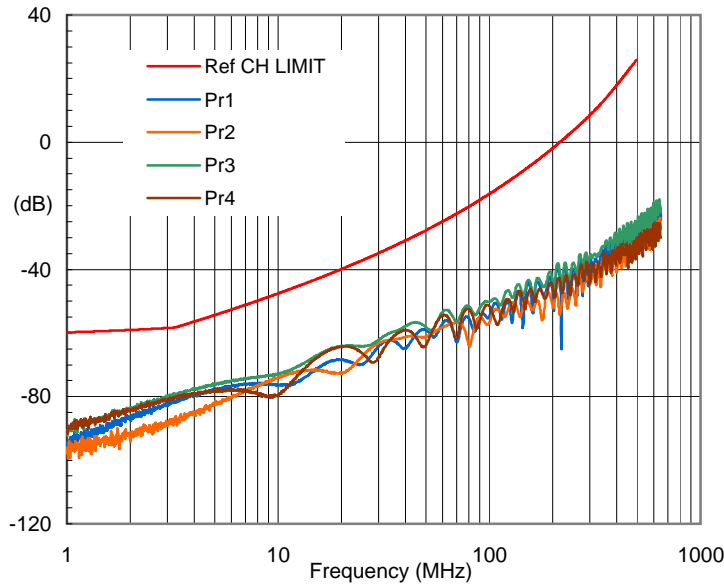

**NOTE:** Limit line/values provided for reference ONLY and are extrapolated from PSNEXT Loss and IL limit requirements.  $psACR_{limit} = psNEXT_{limit} - IL_{limit}$

Worst Case Margin

	Frequency Point (MHz)	Calculated Margin (dB)	Calculated Value (dB)	CH LIMIT Value (dB)
Swept Freq	3.2	20.7	-79.0	-58.3
Discrete Points	1.00	-37.5	-97.3	-59.8
	4.00	-28.8	-85.3	-56.5
	8.00	-29.2	-79.1	-49.9
	10.00	-32.0	-79.6	-47.6
	16.00	-29.4	-71.9	-42.5
	20.00	-32.8	-72.7	-39.9
	25.00	-32.7	-69.9	-37.2
	31.25	-31.3	-65.6	-34.3
	62.50	-33.4	-57.8	-24.3
	100.00	-40.5	-56.8	-16.3
	200.00	-50.2	-52.1	-1.9
	250.00	-50.5	-46.8	3.6
	300.00	-53.1	-44.6	8.5
	400.00	-58.9	-41.0	17.8
	500.00	-61.7	-35.6	26.1
	650.00		-30.0	n/a

Power Sum (PS) ACR as measured from the WORK AREA (WA)

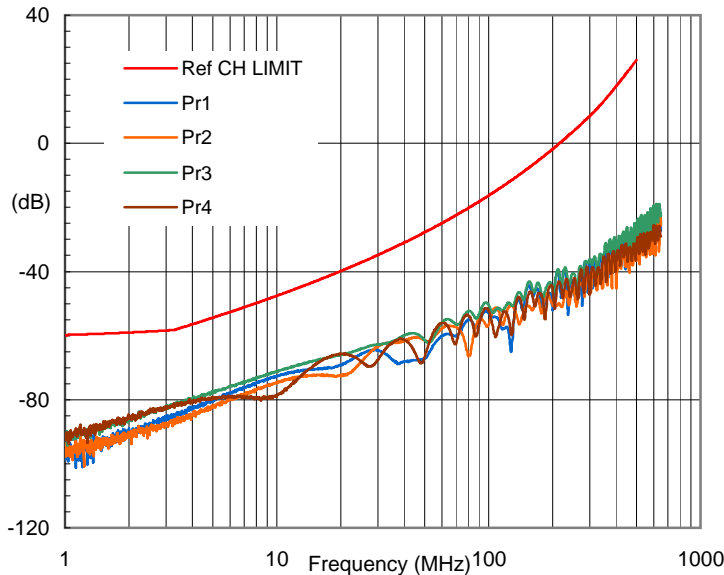

Worst Case Margin

	Frequency Point (MHz)	Calculated Margin (dB)	Calculated Value (dB)	CH LIMIT Value (dB)
Swept Freq	3.8	22.6	-79.4	-56.9
Discrete Points	1.00	-38.6	-98.4	-59.8
	4.00	-28.3	-84.8	-56.5
	8.00	-29.8	-79.6	-49.9
	10.00	-31.3	-78.9	-47.6
	16.00	-29.7	-72.2	-42.5
	20.00	-32.8	-72.7	-39.9
	25.00	-31.1	-68.3	-37.2
	31.25	-31.5	-65.8	-34.3
	62.50	-35.3	-59.6	-24.3
	100.00	-40.2	-56.6	-16.3
	200.00	-49.7	-51.6	-1.9
	250.00	-48.1	-44.4	3.6
	300.00	-55.8	-47.3	8.5
	400.00	-61.4	-43.5	17.8
	500.00	-62.1	-36.0	26.1
	650.00		-29.0	n/a